

Computer Simulation Helps Reduce Touch Temperatures in New Printer

Francisco Zirilli, Ph.D., Principal Engineer

Xerox Corporation

Rochester, New York

Computer simulation helped engineers at Xerox Corporation reduce touch temperatures in a new color printer in order to ensure customer safety.¹ The fuser roll in a laser printer must be quite hot to fix the toner image to the paper. This creates a challenge in preventing free convection from raising the temperature of customer accessible surfaces in the printer to a level that would cause discomfort or injury. Building and testing a physical model to precisely determine touch temperatures is a time-consuming process that can significantly delay new product introduction in the fast-paced laser printer market. In the early product development phase of a new printer, Xerox engineers used computational fluid dynamics (CFD) to precisely determine fuser roll temperatures and identify flow patterns that cause high temperatures. They used the simulation to identify several design modifications that changed the flow inside the case to lower surface temperatures to acceptable levels. They also used the temperature predictions to select the material for customer accessible components. The use of computer simulation helped to provide a better understanding of flow patterns and made it possible to try more design alternatives than would have been possible with physical testing alone.

Thermal design challenges

Fusing, the process in which the transferred toner image is fixed to the paper, is the last step in the xerographic process. Fusing the toner to the paper is generally done by passing the paper through a set of rolls, which are forced to make contact with each

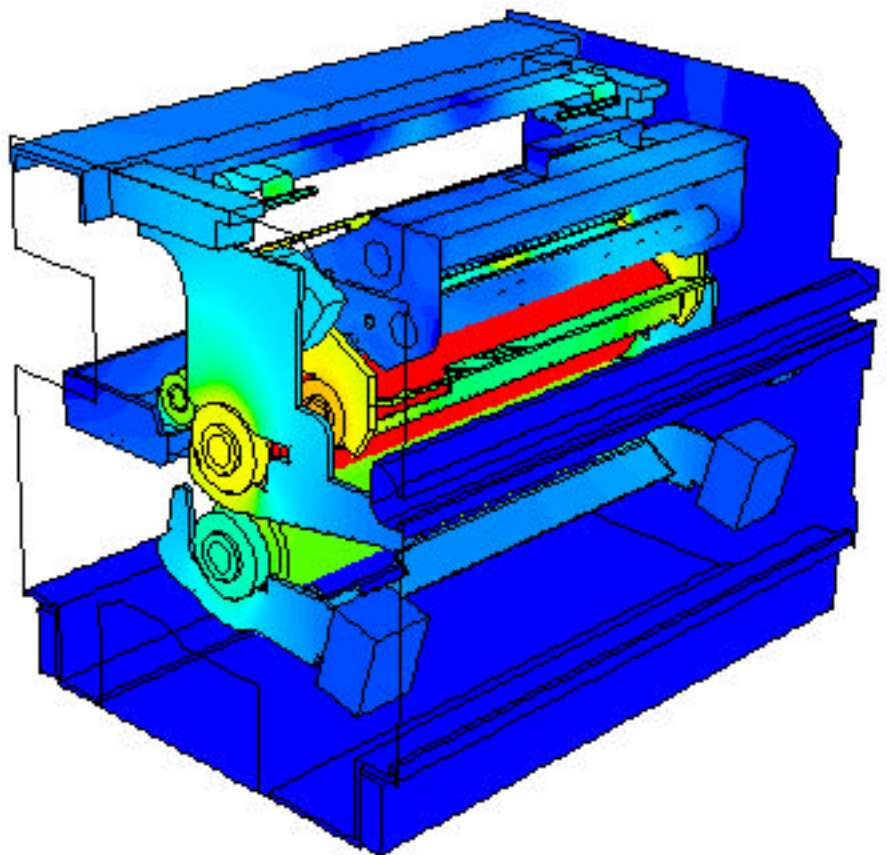

Figure 1: Temperature distribution of the fuser system viewed from paper exit. (Some components removed for clarity.)

other. The roll in direct contact with the toner is referred to as the fuser roll. It usually consists of a hollow aluminum core coated with a rubber compound. This roll is heated internally using a radiant lamp. The opposing roll is called the pressure roll, and is made from solid steel. Successful fixing of the toner depends on maintaining the right surface temperature of the fuser roll and toner thermal properties. In the event of a paper jam, the customer may need to access certain areas in the fuser region of the printer. By design, any surface that the customer needs to come in contact with during jam clearance may not exceed the touch temperatures.

The traditional approach in addressing these issues is to wait until the prototype is constructed and perform physical measurements. If tests indicate that the temperatures are too high, the design is modified in an effort to reduce them, and a new prototype is built and tested. One problem with this approach is that building each prototype is expensive and takes a considerable amount of time. Another problem is that while it is possible to accurately measure the surface

temperature of the fuser roll, physical tests provide little or no information about the flow patterns inside the housing of the printer that play a major role in determining these temperatures. Without understanding these flows, engineers often have to rely upon intuition and "guesstimates" in making design changes in an effort to lower the surface temperatures.

Advantages of simulation

For these reasons, Xerox engineers have turned to CFD, which provides fluid velocity, temperature, and other relevant variables throughout the solution domain for problems with complex geometries and boundary conditions. As part of the analysis, a researcher may change the system geometry or the boundary conditions and view the effect on fluid flow patterns, temperatures, or the distributions of other variables. Xerox engineers use FLUENT CFD software from Fluent Incorporated, Lebanon, New Hampshire, because its graphical user interface greatly reduces the amount of time and training

required to set up the analysis. FLUENT's parallel processing capabilities take full advantage of workstations with multiple processors to reduce computational time to a degree that is almost linear with the number of processors available. For this simulation, engineers used a Sun Ultra 60 dual-processor workstation, and solved the model in about 36 hours.

Xerox engineers began the analysis process by exporting IGES files of the design geometry from the computer aided design (CAD) software in which their geometry was defined. They used GAMBIT, the Fluent preprocessor, to simplify the geometry and build an unstructured mesh of approximately 1.74 million cells of the open areas inside the printer housing where flow can occur. Their model considered both conduction and free convection heat transfer. Temperatures were

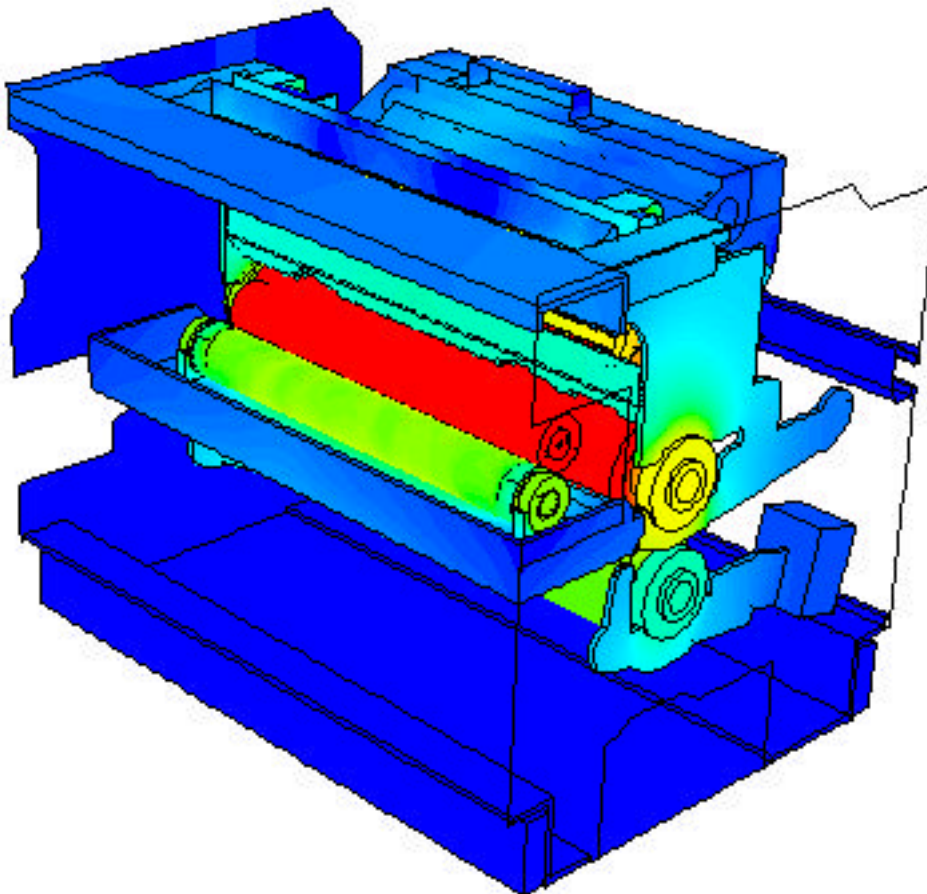

Figure 2: Temperature distribution of the fuser system viewed from the paper entrance. (Some components removed for clarity.)

specified for the surface of the roll in order to avoid the additional computational time needed to model the conduction inside the roll. They solved the model in two different ways. A laminar flow solution was performed that was based on the Boussinesq buoyancy approximation. A turbulent solution was also performed that used a turbulence model that includes the effects of buoyancy. When they compared the simulations with physical experiments, both methods provided accurate results within 10% of experimental results, so they used the first approach for subsequent analyses because it requires less computational time.

Iterating to an optimal design

The model predicted the temperature of customer accessible components and the flow patterns that produced the high temperatures. This gave engineers all the information they needed to either redesign the customer accessible components or shield them from the high temperature sources. The simulation showed that natural convection was the primary driver for carrying the heat from the fuser roll to the ends of the printer compartment. Portions of the pins and brackets that are touched by the customers in clearing a paper jam reached unacceptably high temperatures. The analysis also showed the flow velocity distribution throughout the compartment. This information made it relatively easy for Xerox engineers to reposition these parts to move them out of the airstream. Engineers created several design iterations by changing the model and rerunning the analysis until they found a configuration that maintained the temperatures at acceptable levels. Because the thermal conductivity of a material has a significant impact on the perceived touch temperature, they also used the results of the analysis to specify materials for user accessible components.

This application demonstrates how CFD can provide dramatic advantages over traditional build and test methods. CFD makes it possible to evaluate the performance of concept designs in much less time and at a far lower cost than traditional build-and-test methods. In addition, CFD provides substantially more information that helps engineers understand why a design does or does not work as intended. Before a new printer is prototyped, engineers now optimize the design in detail without investing time

and money in building prototypes for each design modification. The result is that the company is able to provide its customers with safer and better-performing products.

¹Xerox's new DocuColor iGen3 provides unparalleled speed, productivity, image quality, and paper-handling capabilities. The DocuColor iGen3 prints with the traditional look and feel of offset. It runs at 100 pages per minute and will produce 6,000 full-color 8½" x 11" impressions per hour - almost 50 percent faster than competitive products. The printer is available with a choice of two controllers: the Xerox DocuSP controller and the Creo Spire Color Server. The iGen3 was developed with both the environment and the operator in mind. The digital production press uses non-toxic dry inks and generates no hazardous waste, meeting government requirements for ozone, chemical and electromagnetic emissions, and noise. Many of the iGen3's replaceable units are designed for reuse or recycling.